

Preface

Why normalization?

Over the years I had been bothered by selecting material for teaching several one-semester courses. When I taught senior undergraduate students *a first course in (algebraic) number theory*, or when I taught first-year graduate students *an introduction to algebraic geometry*, students strongly felt the lack of some preliminaries on commutative algebra; while I taught first-year graduate students *a course in commutative algebra* by quoting some nontrivial examples from number theory and algebraic geometry, often times I found my students having difficulty understanding. The problem is that in a short semester there is not enough time to go through the significant background material needed in my course (if you are an instructor of mathematics, can you ask your students to find and read those material themselves and do they usually follow?).

Based on my lecture notes on (algebraic) number theory, algebraic geometry, and commutative algebra used at Shaanxi Normal University and Bilkent University, I decided to fuse several things into one — the presentation of this book. As a consequence, the text consists of five chapters that are designed for a (one-semester) common course taken by senior undergraduate students or by first-year graduate students in mathematics. The goal is to introduce to the students the concrete source of commutative

algebra through the following diagram:

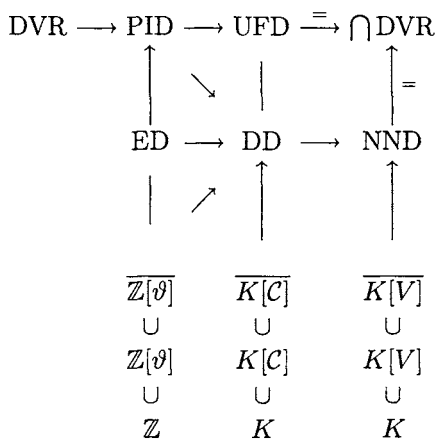

where

DVR = Discrete valuation ring,

PID = Principal ideal domain,

UFD = Unique factorization domain,

ED = Euclidean domain,

DD = Dedekind domain,

NND = Normal Noetherian domain,

$\overline{\mathbb{Z}[\vartheta]}$ = The integral closure of $\mathbb{Z}[\vartheta]$ (or equivalently the integral closure of \mathbb{Z}) in the number field $K = \mathbb{Q}(\vartheta)$,

$\overline{K[\mathcal{C}]}$ = The normalization (or integral closure) of the coordinate ring $K[\mathcal{C}]$ of an algebraic curve \mathcal{C} in its field of rational functions $K(\mathcal{C})$, and

$\overline{K[V]}$ = The normalization (or integral closure) of the coordinate ring $K[V]$ of an irreducible algebraic set V in its field of rational functions $K(V)$.

Or more precisely, in terms of *normal (normalized) structure* the lectures demonstrate how to get to the center of commutative algebra by recognizing the roles that $\overline{\mathbb{Z}[\vartheta]}$, $\overline{K[\mathcal{C}]}$ and $\overline{K[V]}$ play in number theory and algebraic geometry, so that, after reading this volume, interested readers may read a course in algebraic number theory at a higher level, or start an advanced course in algebraic geometry with a better background.

I assume that the reader has taken the undergraduate courses including *Linear Algebra* and *A First Course in Abstract Algebra* (Galois theory may not be included). Moreover, very little about topological space is needed

to understand the Zariski topology in Chapter 5. Other than these prerequisites, the book is self-contained.

Exercises are given at the end of each section. Though most of the exercises mainly test the understanding of the text in the usual way, the reader is involved in providing proofs and in working problems that have not been completely solved in the text; and furthermore, students are asked to extend some of the theory that is essential for the subsequent sections.

Huishi Li