

Some Recent Results on Epidemic Dynamics Obtained by Our Group

Zhien Ma

Department of Applied Mathematics, Xi'an Jiaotong University

Shaanxi 710049, China

E-mail: zhma@mail.xjtu.edu.cn

Abstract

The goal of this synthetic paper is to introduce a part of research directions on epidemic dynamics investigated by our group and our main results during the past several years. Before this, some basic knowledge on epidemic dynamics will be introduced which may be helpful to those readers who are not familiar with the mathematical modeling on Epidemiology.

1 Basic knowledge on epidemic dynamics

Epidemic dynamics is an important method of studying the spread of infectious disease qualitatively and quantitatively. It is based on the specific property of population growth, the spread rules of infectious diseases, and the related social factors, etc., to construct mathematical models reflecting the dynamic properties of infectious diseases, to analyze the dynamical behavior and to do some simulations. The research results are helpful to predict the developing tendency of the infectious disease, to determine the key factors of the spread of infectious disease and to seek the optimum strategies of preventing and controlling the spread of infectious diseases. In contrast with classic biometrics, dynamical methods can show the transmission rules of infectious diseases from the mechanism of transmission of the disease, so that people may know some global dynamic behavior of the transmission process. Combining statistics methods and computer simulations with dynamic methods could make modeling and the original analysis more realistic and more reliable, make the comprehension for spread rule of infectious diseases more thorough.

Now, the popular epidemic dynamic models are still so called compartmental models which were constructed by Kermack and Mckendrick in 1927^[1] and is developed by many other biomathematicians. In the

K-M model, the population is divided into three compartments: susceptible compartment S , in which all individuals are susceptible to the disease; infected compartment I , in which all individuals are infected by the disease and have infectivity; removed compartment R , in which all the individuals recovered from the class I and have permanent immunity. Three assumptions they did as follows:

(1) The disease spread in a closed environment, no emigration and immigration, and is no birth and death in population, so the total population remains a constant k , i.e. $S(t) + I(t) + R(t) \equiv k$.

(2) The infective rate of an infected individual is proportional to the number of susceptible, the coefficient of the proportion is a constant β , so that the total number of new infected at time t is $\beta S(t)I(t)$.

(3) The recovered rate is proportional to the number of infected, and the coefficient of proportion is a constant γ . So that the recovered rate at time t is $\gamma I(t)$.

According to the three assumptions above, it is easy to establish the epidemic model as follows

$$(K-M) \quad \begin{cases} \frac{dS}{dt} = -\beta SI, \\ \frac{dI}{dt} = \beta SI - \gamma I, \\ \frac{dR}{dt} = \gamma I, \end{cases} \quad S(t) + I(t) + R(t) \equiv k.$$

Now, let us explain some basic concepts on epidemiological dynamics.

1.1 Adequate contact rate and incidence

It is well-known that the infections are transmitted through the contact. The number of times an infective individual contacts the other members in unit time is defined as **contact rate**, which often depends on the number N of individuals in the total population, and is denoted by function $U(N)$. If the individuals contacted by an infected individual are susceptible, then they may be infected. Assume that the probability of infection by every time contact is β_0 , then function $\beta_0 U(N)$ is called the **adequate contact rate**, which shows the ability of an infected individual infecting others (depending on the environment, the toxicity of the virus or bacterium, etc.). Since, except the susceptible, the individuals in other compartments of the population can't be infected when they contact with the infectives, and the fraction of the susceptibles in total population is S/N , so the mean adequate contact rate of an infective to the susceptible individuals is $\beta_0 U(N)S/N$, which is called the **infection**

rate. Further, the number of new infected individuals yielding in unit time at time t is $\beta_0 U(N)S(t)I(t)/N(t)$, which is called the **incidence of the disease**.

When $U(N) = kN$, that is, the contact rate is proportional to the size of total population, the incidence is $\beta_0 k S(t)I(t) = \beta S(t)I(t)$ (where $\beta = \beta_0 k$ is defined as the transmission coefficient) which is called **bilinear incidence or simple mass-action incidence**. When $U(N) = k'$, that is, the contact rate is a constant, the incidence is $\beta_0 k' S(t)I(t)/N(t) = \beta S(t)I(t)/N(t)$ (where $\beta = \beta_0 k'$) which is called **standard incidence**, for instance, the incidence formulating the sexually transmitted disease is often of standard type. Two types of incidence mentioned above are often used, but they are special for the real cases. In recent years, some contact rates with saturate feature between them are proposed, such as $U(N) = \alpha N/(1 + \omega N)^{[2]}$, $U(N) = \alpha N/(1 + bN + \sqrt{1 + 2bN})^{[3]}$. In general, the saturate contact rate $U(N)$ satisfies the following conditions:

$$U(0) = 0, U'(N) \geq 0, (U(N)/N)' \leq 0, \lim_{N \rightarrow \infty} U(N) = U_0.$$

Besides, some incidences, which are much more plausible for some special cases, are also introduced, such as $\beta S^p I^q$, $\beta S^p I^q / N^{[4,5]}$.

1.2 Basic reproduction number

Basic reproduction number, denoted by R_0 , represents the average number of secondary infectious infected by an individual of infectives during whose whole course of disease in the case that all the members of the population are susceptible. According to this meaning, it is easy to understand that if $R_0 < 1$ then the infectives will decrease so that the disease will go to extinction; if $R_0 > 1$ then the infectives will increase so that the disease can not be eliminated and usually develop into an endemic.

From the mathematical point of view, usually when $R_0 < 1$, the model has only disease free equilibrium $E_0(S_0, 0)$ in the SOI plane, and E_0 is globally asymptotically stable; when $R_0 > 1$, the equilibrium becomes unstable and usually a positive equilibrium $E^*(S^*, I^*)$ appears. E^* is called an endemic equilibrium and in this case it is stable. Hence, if all the members of a population are susceptible in the beginning, then $R_0 = 1$ is usually a threshold whether the disease go to extinction or go to an endemic.

Example Consider the following model:

$$(M_1) : \begin{cases} \frac{dS}{dt} = \Lambda - \beta SI - bS, \\ \frac{dI}{dt} = \beta SI - bI - \gamma I, \\ \frac{dR}{dt} = \gamma I - bR, \end{cases}$$

where b is the natural death rate, γ is the recovered rate, Λ is recruitment.

Let $\frac{\Lambda}{b} = k$, consider the first two equation we have

$$(M'_1) : \begin{cases} \frac{dS}{dt} = bk - \beta SI - bS, \\ \frac{dI}{dt} = \beta SI - (b + \gamma)I. \end{cases}$$

Let $R_0 = \frac{\beta k}{b + \gamma}$, it is easy to see that when $R_0 < 1$, the system has only one disease free equilibrium $E_0(k, 0)$ and it is stable; when $R_0 > 1$, besides E_0 there is a positive equilibrium $E^* \left(\frac{b + \gamma}{\beta}, \frac{b[\beta k - (b + \gamma)]}{\beta(b + \gamma)} \right)$, and, in this case, E_0 is unstable, E^* is stable, the endemic appears. So $R_0 = 1$ is a threshold to distinguish the disease extinction or persistence.

From model (M_1) we can see that

$$\frac{dN}{dt} = b(k - N), \quad N(t) = S(t) + I(t) + R(t).$$

Hence, the total number of the population is k , and βk should be the number of secondary infectious infected by an individual of infectives per unit time when the number of susceptible is k . From the second equation of the system M'_1 we can see that $1/(b + \gamma)$ is the average course of the disease. Therefore, $R_0 = \beta k/(b + \gamma)$ is the average secondary infectious infected by an individual of the infectives during whose whole course of disease, that is just the reproduction number.

It should be indicated that the reproduction number is not always equivalent to the threshold mentioned above.

2 Epidemic models with vaccination

So far, there are two effective methods to prevent and control the spread of infection, which are vaccination and quarantine. To model the transmission of the infection under vaccination, ordinary differential equations, delay differential equations, and pulse differential equations are often used.

For investigating dynamic behavior of an epidemic model with vaccination, one usually use a SIR compartment model and remove a part of newborns or susceptibles from susceptible class S directly into the removed class R due to vaccination. But if the immunity caused by the vaccination is temporary and the periods of immunity loss from vaccinated and recovered are not the same, then another compartment V should be introduced.

(1) SIS-VS model

The following Figure 2.1 describes an SIS-VS model, where A is newborns per unit time, q is a fraction of vaccinated for the newborns, p is the proportional coefficient of vaccinated for the susceptibles, $Q(t)$ is the probability that an individual remains in the class V at least t time units before returning to the class S , d and α are the natural death rate and death rate due to disease, respectively.

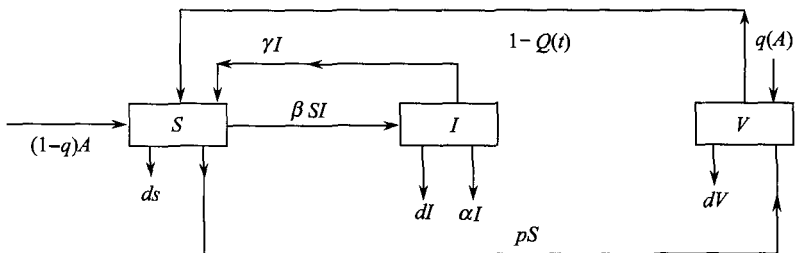

Figure 2.1: The flowchart of an SIS-VS model.

From the flowchart, we may write down the model as follows

$$(M_2) : \begin{cases} \frac{dI}{dt} = \beta SI - (d + \alpha + \gamma)I, \\ V = V_0(t) + \int_0^t [qA + pS(u)]Q(t-u)e^{-d(t-u)} du, \\ \frac{dN}{dt} = A - dN - \alpha I, \end{cases}$$

where $V_0(t)$ is the number of individuals who have already remained in the class V at time $t = 0$.

If the probability Q is exponential distribution, i.e., $Q = e^{-\epsilon t}$, constant $\epsilon > 0$ is the immunity loss rate, then the model (M_2) becomes

$$(M_2^1) : \begin{cases} \frac{dS}{dt} = (1-q)A - \beta SI - (p+d)S + \gamma I + \epsilon V, \\ \frac{dI}{dt} = \beta SI - (d + \alpha + \gamma)I, \\ \frac{dV}{dt} = qA + pS - (\epsilon + d)V. \end{cases}$$

If $Q = \begin{cases} 1, & t \in [0, \tau) \\ 0, & t \geq \tau \end{cases}$, then model (M_2) becomes

$$(M_2^2) : \begin{cases} \frac{dS}{dt} = (1 - q)A - (p + d)S - \beta SI + \gamma I \\ \quad \quad \quad + [qA + pS(t - \tau)]e^{-d\tau}, \\ \frac{dI}{dt} = \beta SI - (d + \alpha + \gamma)I, \\ \frac{dV}{dt} = qA + pS - [qA + pS(t - \tau)]e^{-d\tau} - dV, \end{cases}$$

where τ is the period of immunity.

For model (M_2^1) , let $N = S + I + V$, we consider its replacement:

$$(\bar{M}_2^1) : \begin{cases} \frac{dI}{dt} = I[\beta(N - I - V) - (d + \gamma + \alpha)], \\ \frac{dV}{dt} = qA + p(N - I) - (p + d + \varepsilon)V, \\ \frac{dN}{dt} = A - dN - \alpha I. \end{cases}$$

The following are the main results of the system (M_2^1) .

Theorem 1^[6] Let $R_{01} = \frac{A\beta[\varepsilon + d(1 - q)]}{d(d + \gamma + \alpha)(d + \varepsilon + p)}$.

If $R_{01} \leq 1$ then the system (\bar{M}_2^1) has only a disease free equilibrium $E_0 \left(0, \frac{A(dq + p)}{d(d + \varepsilon + p)}, \frac{A}{d}\right)$, and it is globally asymptotically stable; if $R_{01} > 1$, E_0 is unstable, and there is an endemic equilibrium $E^*(I^*, V^*, N^*)$ which is locally stable. Moreover, E^* is globally asymptotically stable if $R_{01} > 1$ and there exist two positive constants m and n such that the matrix M is positive definite, where

$$M = \begin{pmatrix} \beta m & \frac{\beta m + n\beta}{2} & \frac{\alpha - \beta m}{2} \\ \frac{\beta m + n\beta}{2} & n(p + d + \varepsilon) & \frac{np}{2} \\ \frac{\alpha - \beta m}{2} & -\frac{np}{2} & d \end{pmatrix}.$$

For the model (M_2^2) , since V does not appear explicitly in the first two equations, we need only to discuss the system consisted of the first two

equations.

$$(\bar{M}_2^2) : \begin{cases} \frac{dS}{dt} = A(1-q) - \beta SI - (d+p)S + \gamma I \\ \quad + [qA + pS(t-\tau)]e^{-d\tau}, \\ \frac{dI}{dt} = \beta SI - (d+\gamma+\alpha)I. \end{cases}$$

Theorem 2^[7] Let

$$R_{02} = \frac{\beta A[1 - q(1 - e^{-d\tau})]}{(d + \alpha + \gamma)[d + p(1 - e^{-d\tau})]} = \frac{\beta S_{02}}{d + \alpha + \gamma}.$$

If $R_{01} \leq 1$, the system (\bar{M}_2^2) has only a disease free equilibrium $E_0(S_{02}, 0)$, it is globally asymptotically stable; if $R_{02} > 1$, E_0 is unstable, and the endemic equilibrium $E^*(S^*, I^*)$ appears, which is globally asymptotically stable, where

$$S_{02} = \frac{A[1 - q(1 - e^{-d\tau})]}{d + p(1 - e^{-d\tau})}, \quad S^* = \frac{d + \alpha + \gamma}{\beta},$$

$$I^* = \frac{(d + \alpha + \gamma)[d + p(1 - e^{-d\tau})]}{\beta(d + \alpha)} (R_{02} - 1).$$

(2) SIS-VS model with efficiency of vaccine

In the reality, the efficiency of every type of vaccines may not be 100%, which means that even some of susceptibles have been vaccinated, they still have a certain probability to be infected by the disease. In this case the flowchart of the epidemic may be described by Figure 2.2.

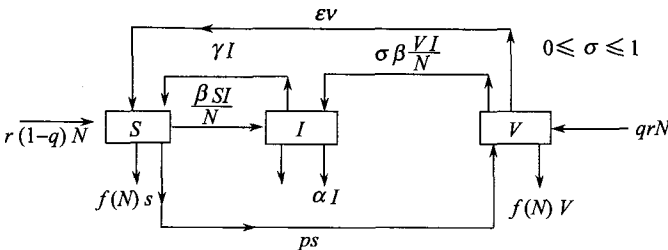

Figure 2.2: The flowchart of an SIS-VS model.

In this model, we assume that the natural death rate is density dependent to the population, i.e., it is a function of N ; the disease spreads in the form of standard incidence; the average number of adequate contact of an infective and a vaccinated individual per unit time are β and $\sigma\beta$ respectively, $0 \leq \sigma \leq 1$, the fraction σ reflects the effect of reducing

the infection due to vaccination, $\sigma = 0$ means that the vaccine is completely effective in preventing infection. The other parameters are easy to be understood as before.

According to the flowchart, the model can be written as

$$(M_3) : \begin{cases} \frac{dS}{dt} = r(1-q)N - \beta \frac{SI}{N} - [p + f(N)]S + \gamma I + \varepsilon V, \\ \frac{dI}{dt} = \beta(S + \sigma V) \frac{I}{N} - [\gamma + \alpha + f(N)]I, \\ \frac{dV}{dt} = rqN + pS - \sigma \beta \frac{IV}{N} - [\varepsilon + f(N)]V. \end{cases}$$

Adding the three equations together gives

$$\frac{dN}{dt} = N[r - f(N)] - \alpha I.$$

Taking the transformation $x = \frac{S}{N}, y = \frac{I}{N}, z = \frac{V}{N}$, we obtain

$$(M_4) : \begin{cases} \frac{dx}{dt} = r(1-q) - (\beta - \alpha)xy - (p+r)x + \gamma y + \varepsilon z, \\ \frac{dy}{dt} = y[\beta x + \alpha y + \beta \sigma z - (r + \alpha + \gamma)], \\ \frac{dz}{dt} = rq + px - (\varepsilon + r)z + (\alpha - \sigma \beta)yz, \\ x + y + z = 1. \end{cases}$$

We need only to consider the system consisted of the second and third equations, denote it by (M_4) .

Theorem 3 ^[8] Let $R_0 = \frac{\beta[\varepsilon + \sigma p + r(1 - (1 - \sigma)q)]}{(\alpha + r + \gamma)(p + \varepsilon + r)}$.

i) If $R_0 > 1$, the endemic equilibrium $E^*(y^*, I^*)$ exists and globally asymptotically stable;

ii) If $R_0 < 1, \alpha < \sigma \beta, \beta > r + \gamma + \alpha, B > 2\sqrt{AC}$, there exist two endemic equilibria $E_1^*(y_1^*, z_1^*)$ and $E_2^*(y_2^*, z_2^*)$ ($y_1^* < y_2^*, z_1^* > z_2^*$) and two stable manifolds of P_1^* which divide the region $D = \{(y, z) | y \geq 0, z > 0, y + z < 1\}$ into two parts D_1 and D_2 , where $P_2^* \notin D_1, P_2^* \in D_2$ such that $\lim_{t \rightarrow \infty} (y(t), z(t)) = (0, z_0)$ when $(y(0), z(0)) \in D_1$, and

$\lim_{t \rightarrow \infty} (y(t), z(t)) = (y_2^*, z_2^*)$ when $(y(0), z(0)) \in D_2$, where

$$A = (\alpha - \sigma\beta)(\beta - \alpha),$$

$$B = \alpha(p + \varepsilon + \gamma + \alpha + 2r)$$

$$- \beta[(\alpha + r + \varepsilon) - \sigma(\beta - r - \alpha + \gamma - p)],$$

$$C = \beta(p + r + \varepsilon) - \beta(1 - \sigma)(rq + p) - (p + r + \varepsilon)(r + \alpha + \gamma)$$

$$= (p + r + \varepsilon)(r + \alpha + \gamma)(R_0 - 1).$$

iii) If $R_0 < 1$, $\alpha < \sigma\beta$, $\beta > r + \gamma + \alpha$, $B = 2\sqrt{AC}$, there exist an endemic equilibrium E_3^* and two stable manifolds of equilibrium E_3^* , which divide the region D into two parts D_1 and D_2 where D_1 is above D_2 , such that $\lim_{t \rightarrow \infty} (y(t), z(t)) = (0, z_0)$ when $(y(0), z(0)) \in D_1$, and $\lim_{t \rightarrow \infty} (y(t), z(t)) = (y^*, z^*)$ when $(y(0), z(0)) \in D_2$.

iv) If $R_0 = 1$, $\alpha < \sigma\beta$, $B > 0$, then there exists an endemic equilibrium E_4^* , which is globally asymptotically stable.

v) If the parameters of model (\bar{M}'_4) don't satisfy the cases of i)-iv), then the disease free equilibrium $E_0(0, z_0)$ is globally asymptotically stable.

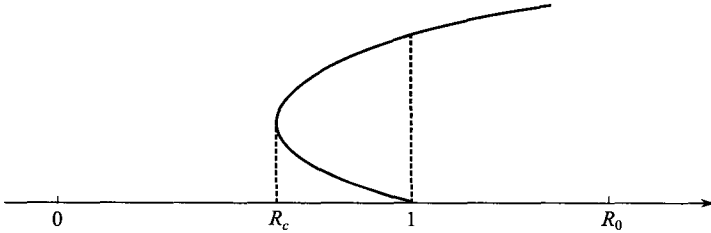

Figure 2.3: The diagram of backward bifurcation.

It is worth to indicate that when

$$0 < \sigma_c \leq \sigma < \sigma_1 < 1,$$

the two endemic equilibria still exist even if $R_0 < 1$. In this case the disease can still exist until $R_0 < R_c$, where $R_c = \frac{\beta[\varepsilon + \sigma_c p + r(1 - (1 - \sigma_c)q)]}{(\alpha + r + \gamma)(p + \varepsilon + r)}$, σ_c is a root of the equation $B = 0$, ($\sigma_2 < \sigma_c < \sigma_1 < 1$). This phenomenon is called backward bifurcation. Hence, in order to prevent and control the spread of disease, estimating accurately the efficiency of the vaccine is necessary and important.

(3) The impulsive vaccination

Suppose that the vaccination is given to the susceptible group in a time sequence, then the model should be considered as an impulsive differential system. The following is an SIR model with impulsive vaccinations.

$$(M_5) : \begin{cases} \frac{dS}{dt} = \mu k - \beta SI - \mu S \\ \frac{dI}{dt} = \beta SI - (\mu + \alpha)I - \lambda I \\ \frac{dR}{dt} = \lambda I - \mu R \quad (t \neq k, k = 1, 2, \dots) \end{cases} \begin{cases} S(k^+) = (1 - p)S(k) \\ I(k^+) = I(k) \\ R(k^+) = R(k) + pS(k), \\ k = 0, 1, 2, \dots \end{cases}$$

here $f(k^+) = \lim_{t \rightarrow k^+} f(t)$, $f(k) = \lim_{t \rightarrow k^-} f(t)$. p is a proportion of inoculation, μ and α are the death rates due to nature and disease respectively, λ is the recovered rate.

For the model (M_5) we obtained the following results

Theorem 4^[9] Let $R_0 = \frac{\beta}{\mu + \alpha + \lambda} \int_0^1 S_0(t)dt$, where

$$\int_0^1 S_0(t)dt = k - \frac{kp(e^\mu - 1)}{\mu(e^\mu - 1 + p)},$$

$(S_0(t), 0, R_0(t))$ is a periodic solution of the model (M_5) with the period 1.

If $R_0 < 1$, then the disease free periodic solution $(S_0(t), 0, R_0(t))$ is globally asymptotically stable.

We also investigated the SIR and SIRS models with impulsive vaccination and obtained some sufficient conditions for the stability of disease free periodic solutions.

3 Epidemic models with quarantine strategy

Quarantine to the infective individuals is another effective measure to prevent and control the spread of infection. The earliest study on the effects of quarantine on the transmission of the infection is achieved by Feng and Thieme^[10,11] and Wu and Feng^[12]. In those papers, they introduced a quarantine compartment Q , and assume that all the infective individuals must pass through the quarantined compartment before going to the removed compartment or back to the susceptible compartment. We considered some more realistic cases^[12]: a part of infective

individuals are quarantined and the others are not quarantined and enter into the susceptible class or directly enter into removed class when they recovery.

We analyzed SIQS and SIQR two types models with three kinds of incidence: simple mass action incidence, standard incidence, and quarantine-adjusted incidence $\frac{\beta SI}{N - Q}$.

Figure 3.1 is the flowchart of an SIQS model with simple mass action incidence. The corresponding model is

$$(M_6) : \begin{cases} \frac{dS}{dt} = A - \beta SI - dS + \gamma I + \varepsilon Q, \\ \frac{dI}{dt} = [\beta S - (\gamma + \delta + d + \alpha)]I, \\ \frac{dQ}{dt} = \delta I - (\varepsilon + d + \alpha)Q. \end{cases}$$

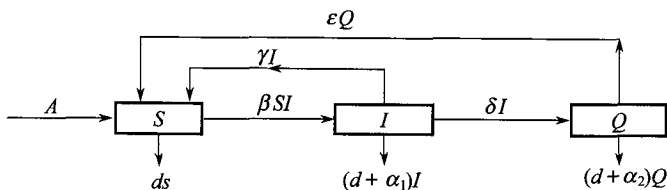

Figure 3.1: The flowchart of an SIQS model.

Theorem 5^[13] Let $R_0 = \frac{\beta A}{\gamma + \delta + d + \alpha}$.

If $R_0 \leq 1$, then the disease free equilibrium $E_0(S_0, 0, 0)$ of the model (M_6) is globally asymptotically stable; if $R_0 > 1$, E_0 is unstable and there exists an endemic equilibrium $E^*(S^*, I^*, Q^*)$ which is globally asymptotically stable.

For the SIQR model with quarantine-adjusted incidence we obtained the following results.

Theorem 6^[13] Consider the model

$$(M_7) : \begin{cases} \frac{dS}{dt} = A - \frac{\beta SI}{S + I + R} - dS, \\ \frac{dI}{dt} = \left[\frac{\beta S}{S + R + I} - (\gamma + \delta + d + \alpha_1) \right] I, \\ \frac{dQ}{dt} = \delta I - (\varepsilon + d + \alpha_2)Q, \\ \frac{dR}{dt} = \gamma I + \varepsilon Q - dR. \end{cases}$$

Let $R_0 = \frac{\beta}{\gamma + \delta + d + \alpha_1}$. If $R_0 \leq 1$ then the disease free equilibrium $E_0 \left(\frac{A}{d}, 0, 0, 0 \right)$ of the model (M_7) is locally stable; if $R_0 > 1$ then E_0 is unstable, the disease is uniformly persistent, and there is an unique endemic equilibrium E^* which is usually locally stable, but Hopf bifurcation can occur for some parameter values, so that E^* is sometimes an unstable spiral and a periodic solution around E^* can occur.

[13] analyzed all six cases (SIQS, SIQR two types models with three kinds of incidence) and found that only the SIQR model with the quarant ine-adjusted incidence may exist a periodic solution around the endemic equilibrium, which is produced by Hopf bifurcation, for all the other five models, the endemic equilibrium is always globally asymptotically stable.

4 Epidemic models with complicated structures

(1) SEIR models with saturating contact rate and more general contact rate.

In general SEIR and SEIRS models cannot be reduced to two dimensional system. For the competitive system the global stability may be obtained by means of the orbital stability, the second additive compound matrix and some methods of ruling out the existence of periodic solution proposed by Muldowney and Li^[14-16]. Using those methods we investigated the following model and the complete results were gained.

Theorem 7^[17] Consider an SEIR model with saturating contact rate $C(N) = \frac{bN}{1 + bN + \sqrt{1 + 2bN}}$ as follows

$$(M_8) : \begin{cases} \frac{dS}{dt} = A - \frac{a_0 SI}{h(N)} - \mu S, \\ \frac{dE}{dt} = \frac{a_0 SI}{h(N)} - \varepsilon_0 E - \mu E, \\ \frac{dI}{dt} = \varepsilon_0 E - \gamma_0 I - \mu I - \alpha_0 I, \\ \frac{dR}{dt} = \gamma_0 I - \mu R, \end{cases}$$

where A is recruitment, E is the exposed class or the latent class. $\frac{1}{\varepsilon_0}$ is the period of latent, $\frac{1}{\gamma_0}$ is the course of disease, μ and α_0 are the

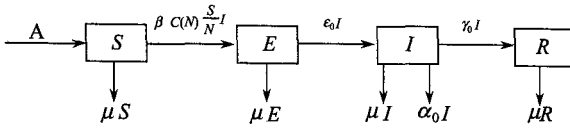

Figure 4.1: The flowchart of an SEIR model.

death rates due to nature and disease, respectively, $h(N) = 1 + bN + \sqrt{1 + 2bN}$, $a_0 = \beta b$.

$$\text{Let } R_0 = \beta C \left(\frac{A}{\mu} \right) \frac{\varepsilon_0}{(\mu + \gamma_0 + \alpha_0)(\mu + \varepsilon_0)}.$$

If $R_0 \leq 1$ then the disease free equilibrium P_0 is globally asymptotically stable; If $R_0 > 1$, then P_0 is unstable and there exists a unique endemic equilibrium P^* which is globally asymptotically stable. We also investigated an SEIR model with a general contact rate and obtained similar results.

(2) Epidemic models with different infective groups

For a certain disease, different infectives may have different infectivities and different recovered rate, in this case, we may partition the infected compartment I into n sub-compartments, denoted by I_i ($i = 1, 2, \dots, n$). We suppose that the individuals in each of the infected sub-compartments may contact and infect the susceptibles and the secondary infectives will enter into different group I_i according to a certain proportion p_i , $\sum_{\alpha=1}^n p_i = 1$. Hence the flowchart and corresponding model are shown in Figure 4.2 and (M_9) .

$$(M_9) : \begin{cases} \frac{dS}{dt} = \mu(S^0 - S) - \sum_{i=1}^n \beta_i I_i S, \\ \frac{dI_i}{dt} = p_i \sum_{i=1}^n \beta_i I_i S - (\mu + \gamma_i) I_i, \\ \frac{dR}{dt} = \sum_{j=1}^n \gamma_j I_j - \delta R, i = 1, 2, \dots, n. \end{cases}$$

Theorem 8^[19] Let $R_0 = S^0 \sum_{i=1}^n \frac{\beta_i p_i}{\mu + \gamma_i}$. If $R_0 < 1$, then the disease free equilibrium of the model (M_{10}) , $E_0(S^0, 0, \dots, 0)$ is globally asymptotically stable; if $R_0 > 1$, then E_0 is unstable and there exists a unique endemic equilibrium $E^*(S^*, I_1^*, \dots, I_n^*)$ which is globally asymptotically stable.

It should be indicated that for the model (M_9) , instead of mass action law incidence if we use standard incidence, then the similar results have

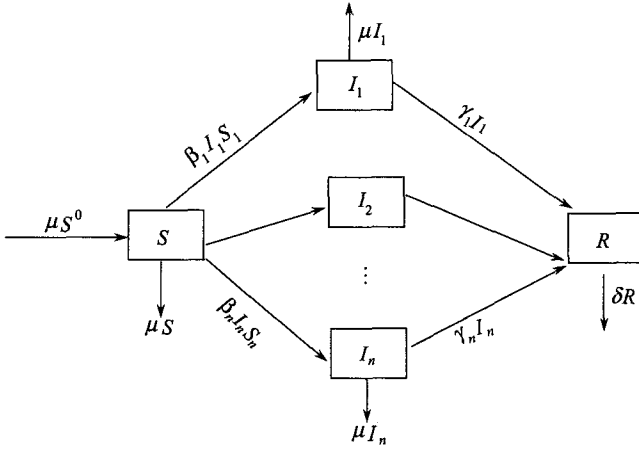

Figure 4.2: The flowchart of a model with different infective groups.

also been obtained provided the reproduction number is taken into $R_0 = \sum_{i=1}^n \frac{\beta_i p_i}{\mu + \gamma_i}$.

For SIS models, if we divide I into n sub-compartments, and suppose that there is no immunity for the individuals in each group I_i ; the recoveries will return to the susceptible group in the different recovered rates. In this case, the model is similar, but analysis for this $n + 1$ -dimensional space is very complicated. We only considered the special case that I is divided only into two sub-compartments and obtained the reproductive number and complete results for the stability of equilibria. Moreover, we also added more demographic effects to assume density-dependent birth and death rates for the population in this simple case, and obtained the similarly complete results as well.

For the SIR or SIS models with n -stages of infections as shown in Figure 4.3.

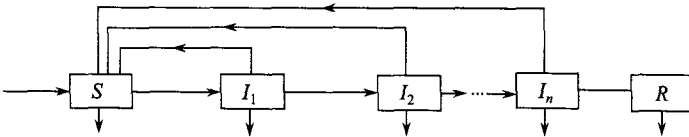

Figure 4.3: The flowchart of the SIR or SIS models with n -stages of infections.

If the individuals of infectives are divided into n -groups I_i according to their courses of disease, and suppose that each group I_i may contact

with susceptibles and infects them with different infectivities. Of course, all the new infective will enter into the first group I_1 and then develop to the groups I_2, I_3, \dots, I_n successively depending on the courses of disease. For this model, we obtained some results only for three stages.

(3) Epidemic models with different susceptible groups and different infective groups.

Since different susceptibles may have different immunities against the disease, besides different infective groups we sometimes also need to partition the susceptibles into several sub-groups.

[20] investigated an epidemic model in a homosexual population which consists of susceptible and infective individuals. The assumptions are the following: there are two groups of individuals who have different response to disease due to the difference of sexual activities, genetics, immune systems or other factors; the infectives in each group are divided into 2 classes based on the infecting pathogen strains and that susceptibles infected by individuals with a certain pathogen strain have the same pathogen strain; there is no superinfection such that an individual can be infected only by one strain if this individual is infected. We use $s_k, k = 1, 2$ to denote the susceptibles will have sexual activity r_k , which is the number of contacts per individual in group K per unit of time, and use I_k and J_k to denote the infectives with sexual activity k and infected by strain 1 and strain 2, respectively. The dynamics of the disease transmission then are governed by the following model.

$$(M_{10}) \quad \begin{cases} \frac{dS_k}{dt} = \mu_k(S_k^0 - S_k) - (B_k^I + B_k^J) + \gamma_k^I I_k + \gamma_k^J J_k, \\ \frac{dI_k}{dt} = B_k^I - (\mu_k + \gamma_k^I) I_k, \\ \frac{dJ_k}{dt} = B_k^J - (\mu_k + \gamma_k^J) J_k, \end{cases} \quad k = 1, 2,$$

where

$$B_k^I = S_k \gamma_k \beta^I \frac{\sum_{j=1}^2 \gamma_j I_j}{\sum_{j=1}^2 \gamma_j T_j}, \quad B_k^J = S_k \gamma_k \beta^J \frac{\sum_{j=1}^2 \gamma_j J_j}{\sum_{j=1}^2 \gamma_j T_j}$$

are the incidences with $T_k = S_k + I_k + J_k$ being the population size of group k , and other parameters are easy to be understood.

Since

$$\frac{dT_k}{dt} = \mu_k(S_k^0 - T_k),$$

the equilibrium for T_k is S_k^0 , thus the limiting system of model (M_{10}) is

$$(M_{11}) \quad \begin{cases} \frac{dI_k}{dt} = \sigma_k^I (S_k^0 - I_k - J_k) \sum_{j=1}^2 \gamma_j J_j - \nu_k^I I_k, \\ \frac{dJ_k}{dt} = \sigma_k^J (S_k^0 - I_k - J_k) \sum_{j=1}^2 \gamma_j J_j - \nu_k^J J_k, \end{cases}$$

where

$$\sigma_k^u := \frac{\gamma_k \beta^u}{\sum_{j=1}^2 \gamma_j S_j^0}, \quad \nu_k^u := \mu_k + \gamma_k^u, \quad u = I, J.$$

Theorem 9^[20] Let $R^u = \frac{\nu_2^u \sigma_1^u S_1^0 \gamma_1 + \nu_1^u \sigma_2^u S_2^0 \gamma_2}{\nu_1^u \nu_2^u}$
 $= S_1^0 \gamma_1 \frac{\sigma_1^u}{\rho_1^u} + S_2^0 \gamma_2 \frac{\sigma_2^u}{\gamma_2^u}, \quad u = I, J.$

If $R^I \leq 1$ and $R^J \leq 1$, then the disease free equilibrium $E_0(0, 0, 0, 0)$ is globally asymptotically stable; if $R^I > 1$ or $R^J > 1$, then E_0 is unstable.

There exist two types of endemic equilibria for model (M_{11}) , one of which consists of either $E^I(I_1^0, I_2^0, 0, 0)$ or $E^J(0, 0, J_1^0, J_2^0)$ and another has all components positive, $E^*(I_1^*, I_1^*, J_1^*, J_2^*)$. We call the first type of endemic equilibria boundary equilibrium, and the second type coexistence endemic equilibrium.

Theorem 10^[20] The boundary equilibrium $E^I(E^J)$ exists if and only if $R^I > 1$ ($R^J > 1$). If $R^I > 1$ ($R^J > 1$) and $R^J \leq 1$ ($R^I \leq 1$) then the boundary equilibrium $E^J(E^I)$ does not exist and $E^I(E^J)$ is globally asymptotically stable. If both $R^I > 1$ and $R^J > 1$, then when $D_k < 1$ ($D_k > 1$), $E^I(E^J)$ is globally asymptotically stable and $E^J(E^I)$ is unstable, where $D_k = \frac{R_k^J}{R_k^I}, k = 1, 2$.

5 Epidemic models with natural age and infection age structures

As we know, chronological and infection age are very important factors in disease spread and a number of papers have already investigated some epidemic models involved these two age structures^[21,22]. But previous dynamical analysis for many age-structure models were incompleated. The local stability for disease-free steady-state is easy to establish for most age-structure models when the basic reproduction number is less than a unity. The global stability of a stable age distribution, however, is very difficult in general. The following SIS model investigated by us

focuses on the study of the global dynamics of the two-age structure^[23].

$$(M_{12}) \quad \left\{ \begin{array}{l} \frac{\partial S}{\partial a} + \frac{\partial S}{\partial t} = -\mu(a)S(a, t) - G(a, t) + \gamma(a) \int_0^a i(a, c, t)dc \\ S(0, t) = \int_{A_1}^{A_2} b(a, P(t))p(a, t)da \\ S(a, 0) = S_0(a), \quad S(A, t) = 0, \\ \frac{\partial i}{\partial a} + \frac{\partial i}{\partial c} + \frac{\partial i}{\partial t} = -(\mu(a) + \gamma(a))i(a, c, t), \\ i(a, 0, t) = G(a, t), \\ i(A, c, t) = 0, \quad i(a, c, 0) = i_0(a, c), \end{array} \right.$$

where a and c are the chronological age and infection age respectively, the total numbers of the susceptibles $S(t)$ and infectives $I(t)$ at time t are given by $S(t) = \int_0^A S(a, t)da$, $I(t) = \int_0^A \int_0^a i(a, c, t)dcda$, respectively. A is the maximum age and the total population size is $P(t) = S(t) + I(t)$. It is assumed that all newborns are susceptibles and the disease is not fatal, $p(a, t) = S(a, t) + \int_0^a i(a, c, t)dc$ is the entire population density at time t , $P(t) = \int_0^A p(a, t)da$ is the total population size at time t , $b(a, P(t))$ is the density-dependent age-specific birth rate, $S_0(a)$ and $i_0(a, c)$ are the initial distributions, $[A_1, A_2]$ is the fecundity period, $0 < A_1 < A_2 < A$, $\mu(a)$ the age-specific mortality rate, $\gamma(a)$ the age-specific recovery rate, $G(a, t)$ is the rate at which susceptible individuals of age a move over into the infective group per capita and per unit time, and $G(a, t)$ satisfies

$$G(a, t) = (p_\infty(a) - \int_0^a G(a - c, t - c)\pi(a', c)dc) \cdot \int_0^A \int_0^{a'} \lambda(a, a', c)G(a' - c, t - c)\pi(a', c)dcda',$$

where $p_\infty(a)$ is the total population at its demographic steady-state, $\pi(a', c) = \exp(-\int_{a'-c}^{a'} (\mu(c) + \gamma(c))dc)$, $\lambda(a, a', c)$ is the adequate contact rate.

Under the assumption that $\lambda(a, a', c) = \lambda_1(a)\lambda_2(a', c)$, the basic reproduction number is defined to be

$$R_0 = \int_0^A \int_0^{a'} \lambda_1(a' - c)\lambda_2(a', c)p_\infty(a' - c)\pi(a', c)dcda',$$

and the following two main results have been proved ^[23].

Theorem 11^[23] Under some assumptions (see reference [23]) if $\lambda(a, a', c) = \lambda_1(a)\lambda_2(a', c)$, then the disease free steady-state is globally

asymptotically stable if $R_0 \leq 1$, whereas it is unstable and there exists a unique endemic steady-state if $R_0 > 1$.

Theorem 12^[23] Under the same assumptions in Theorem 11, if $\lambda(a, a', c) = \lambda_1(a)\lambda_2(a')e^{-\delta c}$, then the endemic solution is globally asymptotically stable if $R_0 > 1$.

Discrete models in population dynamics have been extensively studied, but the formulation and analysis of discrete models in epidemiology are still in its infancy, especially for discrete epeccimic models with age-structure. The following is a general discrete age-structured SIS epidemic model. The basic reproduction number, global stability of the disease free equilibrium and bifurcation of the endemic equilibrium have been investigated^[24].

$$(M_{13}) \left\{ \begin{array}{l} S_0(t+1) = N_0, \quad I_0(t+1) = 0, \quad t = 0, 1, 2, \dots \\ S_{j+1}(t+1) = p_j S_j(t) - \lambda_j \sum_{k=0}^m \beta_k I_k(t) \frac{S_j(t)}{N_j(t)} + \gamma_j I_j(t), \\ \quad j = 0, 1, \dots, m-1, \\ I_{j+1}(t+1) = p_j I_j(t) + \lambda_j \sum_{k=0}^m \beta_k I_k(t) \frac{S_j(t)}{N_j(t)} - \gamma_j I_j(t), \\ \quad j = 0, 1, \dots, m-1, \\ S_j(0) = S_{j0} \geq 0, \quad I_j(0) = I_{j0} \geq 0, \quad j = 0, 1, \dots, m, \end{array} \right.$$

where $\beta_k \lambda_j$ is the transmission rate between an infective of group k and a susceptible of group j , γ_j is the recovery rate of group j .

Let

$$\begin{aligned} f(x) = & \beta_1 \lambda_0 + \beta_2 (\lambda_1 + \lambda_0 q_1(x)) + \beta_3 (\lambda_2 + \lambda_1 q_2(x) + \lambda_0 q_1(x) q_2(x) + \dots \\ & + \beta_m [\lambda_{m-1} + \lambda_{m-2} q_{m-1}(x) + \lambda_{m-3} q_{m-2}(x) q_{m-1}(x) + \dots \\ & + \lambda_1 q_2(x) q_3(x) \dots q_{m-1}(x) + \lambda_0 q_1(x) q_2(x) \dots q_{m-1}(x)], \end{aligned}$$

where $q_j = q_j(x) = p_j - \gamma_j - x \lambda_j / N_j$, $j = 1, 2, \dots, m-1$.

Define the reproduction number $R_0 = f(0)$, then we have

Theorem 13^[24] For the SIS model (M_{13}) , the disease free equilibrium is globally asymptotically stable if $R_0 < 1$, and it is unstable if $R_0 > 1$. When $R_0 > 1$ and $R_0 - 1$ sufficient small, there exists a small endemic equilibrium.

The dynamical behavior of the general SIS model (M_{13}) is quite complicated. There is no satisfied result on the uniqueness and global stability of the endemic equilibrium. But for the special case $m = 2$, the results we got are quite complete, The basic reproduction number R_{02} has been obtained, and we proved that the disease free equilibrium

is globally stable if $R_{02} > 1$. For $m = 3$, we also obtained some results although the behavior is much more complicated^[24].

6 Epidemic models with time dependent coefficients

In the reality, the growth of population and the transmission of disease often depend on seasons. This implies that the coefficients of epidemic models are often time dependence. In this case the corresponding models become non-autonomous differential systems. First, let us consider an SIR model with births and deaths as follows

$$(M_{14}) \quad \begin{cases} \frac{dS}{dt} = \mu(t) - \mu(t)S - \beta(t)SI, \\ \frac{dI}{dt} = \beta(t)SI - \gamma(t)I - \mu(t)I, \\ \frac{dR}{dt} = \gamma(t)I - \mu(t)R, \end{cases}$$

where we suppose that $\mu(t), \beta(t), \gamma(t)$ are all continuous, have upper bounds and positive lower bounds, and $S(t) + I(t) + R(t) = N(t) = 1$.

From the second equation of the model (M_{14}) we can see that

$$\frac{dI}{dt} = \left[\frac{\beta(t)S}{\gamma(t) + \mu(t)} - 1 \right] [\gamma(t) + \mu(t)] I(t).$$

So if there exists a t_0 such that $\frac{\beta(t_0)}{\gamma(t_0) + \mu(t_0)} < 1$ and $s(t_0) \approx 1$, then $I(t)$ decreases at a neighborhood of t_0 . Hence if we want $I(t)$ decreasing with t for any initial value, we need

$$R_{\max} = \max_t \left[\frac{\beta(t)}{\gamma(t) + \mu(t)} \right] < 1.$$

But to make $R_{\max} < 1$ we will spend much more energy and cost. In the following, we are going to find a preciser condition.

Theorem 14^[25] Let $\bar{R} = \frac{\langle \beta \rangle}{\langle \gamma \rangle + \langle \mu \rangle}$. If $\bar{R} > 1$ then the disease free solution of the model M (denoted by DFS), $S = 1, I = 0, R = 0$ is unstable; if $\bar{R} < 1$, then DFE is globally asymptotically stable, where $\langle f \rangle = \lim_{t \rightarrow +\infty} \frac{\int_0^t f(u) du}{t}$ is called long-term average of the function f , and we assume that $\langle \beta \rangle, \langle \gamma \rangle, \langle \mu \rangle$ all exist.

It is easy to see that if β, γ are all constants, then $\bar{R} = \frac{\beta}{\gamma + \mu}$ is just the basic reproduction number for the corresponding autonomous

system. For the non-autonomous system (M_{14}) , this \bar{R} is actually the basic reproduction number of the long-term average system.

$$(M_{15}) \quad \begin{cases} \frac{dS}{dt} = \langle \mu \rangle - \langle \mu \rangle S - \langle \beta \rangle SI, \\ \frac{dI}{dt} = \langle \beta \rangle SI - \langle \gamma \rangle I - \langle \mu \rangle I, \\ \frac{dR}{dt} = \langle \gamma \rangle I - \langle \mu \rangle R. \end{cases}$$

For the non-autonomous SIS model with extra death rate caused by disease and standard incidence, we also proved that the threshold of the corresponding long-term average system (M_{15}) , $\bar{R} = 1$ is the threshold to distinguish the unstability and global asymptotical stability of the disease free solution of the model.

For the following SIRS model,

$$(M_{16}) \quad \begin{cases} \frac{dN}{dt} = b(t)N - d(t)N - \alpha(t)N + \delta(t)R, \\ \frac{dS}{dt} = b(t)N - d(t)S - \frac{\beta(t)}{N} SI, \\ \frac{dI}{dt} = \frac{\beta(t)}{N} SI - \gamma(t)I - \alpha(t)I - d(t)I, \\ \frac{dR}{dt} = \gamma(t)I - d(t)R - \delta(t)R. \end{cases}$$

We proved that the threshold of the corresponding long-term average system $\bar{R} = \frac{\langle \beta \rangle}{\langle b \rangle + \langle \alpha \rangle + \langle \gamma \rangle}$ is still the threshold to distinguish the unstability and global asymptotical stability of the disease free solution of the model (M_{16}) .

For the following simple SEIRS model with latent compartment E :

$$(M_{17}) \quad \begin{cases} \frac{dS}{dt} = -\beta(t)SI + \delta R, \\ \frac{dE}{dt} = \beta(t)SI - \sigma E, \\ \frac{dI}{dt} = \sigma E - \gamma I, \\ \frac{dR}{dt} = \gamma I - \delta R. \end{cases}$$

Suppose $S(t) + E(t) + I(t) + R(t) \equiv 1$, and $\langle \beta \rangle = \bar{\beta}$ exists. The corresponding long-term average system is

$$(M_{18}) \quad \begin{cases} \frac{dS}{dt} = -\bar{\beta}SI + \delta R, \\ \frac{dE}{dt} = \bar{\beta}SI - \sigma E, \\ \frac{dI}{dt} = \sigma E - \gamma I, \\ \frac{dR}{dt} = \gamma I - \delta R. \end{cases}$$

It is easy to see that for (M_{18}) , the reproduction number is $\bar{R}_0 = \frac{\bar{\beta}}{\gamma}$ and the disease free equilibrium E_0 is globally asymptotically stable if $\bar{R}_0 < 1$, is unstable if $\bar{R}_0 > 1$. For model (M_{17}) , is $\bar{R}_0 = \frac{\bar{\beta}}{\gamma}$ still a threshold to distinguish the stability of disease free solution? Unfortunately, it is not true, an example was given in [25]. But we proved the following result:

Theorem 15^[25] For the model (M_{17}) , if $\bar{R} = \frac{\langle \beta \rangle}{\gamma} < 1$, then the disease free solution of the model is globally asymptotically stable.

Actually for motel (M_{17}) , the threshold should be $\bar{R}_0 = \frac{\sigma \langle W \rangle}{\gamma} = 1$, where $w(t)$ is a solution of the equation $\frac{dw}{dt} = \beta(t) - (\sigma - \gamma)w - \sigma w^2$. It is not solvable, but may be obtained by numerical analysis if it is necessary.

7 Epidemic models combining with population ecology

The theory and application of epidemiology modeling combining with the population ecology was started more than 20 years ago. The 1981 Dablem conference on the population biology of infectious diseases was a seminal in identifying some key questions about the effects of infectious diseases on naturally fluctuating host populations. In 1982, Anderson and May published a book "population biology of infectious diseases^[26]". They also investigated a predator-prey model with disease transmission only in the prey population and bilinear incidence^[27]. The stable periodic oscillation of the two populations has been found in their models. Some other epidemic models of interactive species were discussed in [28 – 31]. Here we just introduce two results obtained by our group.

One is a predator-prey model with infectious disease, the model is

the following:

$$(M_{19}) \quad \begin{cases} \dot{N}_1 = r_1 \left(1 - \frac{N_1}{K_1}\right) N_1 - a_1 N_1 N_2 \\ \dot{S}_1 = \left(b_1 - \frac{a_1 r_1 N_1}{K_1}\right) N_1 - [d_1 + (1 - a_1) \frac{r_1 N_1}{K_1}] S_1 - a N_2 S_1 \\ \quad - \beta_1 \frac{S_1 I_1}{N_1} + \gamma_1 I_1 \\ \dot{I}_1 = \beta_1 \frac{S_1 I_1}{N_1} - \gamma_1 I_1 - [d_1 + (1 - a_1) \frac{r_1 N_1}{K_1}] I_1 - a N_2 I_1, \\ \dot{N}_2 = K a N_1 N_2 - d_2 N_2, \\ \dot{S}_2 = K a N_1 N_2 - \alpha \frac{S_2 I_1}{N_2} - d_2 S_2 - \beta_2 \frac{S_2 I_2}{N_2} + \gamma_2 I_2 \\ \dot{I}_2 = \beta_2 \frac{S_2 I_2}{N_2} - d_2 I_2 + \alpha \frac{S_2 I_1}{N_2} - \gamma_2 I_2. \end{cases}$$

This model has 6 equilibria. By the theoretical analysis, our results imply the following biologic meanings^[32].

(1) If there is no prey initially, then there is never any prey, and predator population goes to extinction.

(2) Suppose that the feeding efficiency k of the predator population is low enough so that the predator population goes to extinction, and if the basic reproduction number R_0 in the isolated prey population is below the threshold, then the disease dies out and the prey population goes to its carrying capacity K_1 ; if R_0 is above the threshold, then the disease in the prey approaches the endemic level and the prey population goes to its carrying capacity K_1 .

(3) Suppose that the feeding efficiency k of the predator population is high enough so that the predator population persists, and if R_1 (R_1 is a basic reproduction number in the prey population when the prey and predator populations are at their persistent equilibria) and R_2 (R_2 is the basic reproduction number for the isolated predator population) are below the thresholds, then the disease dies out and the prey and predator populations go to their usual persistent equilibria; if R_1 is below the threshold but R_2 is above the threshold, then the disease persists in the predator population, but dies out in the prey population; if R_1 is above the threshold, then the disease persists in both the populations. Note that this disease persistence in the predator population occurs even if the basic reproduction number R_2 is below the threshold. Thus even if the disease transmission rate α during the predation process is very small, the disease will persist in the predator population whenever it persists in the prey population.

We also investigated predator-prey SIS model with mass action incidence, predator-prey SIR model with standard or with mass action

incidence^[32].

Another kind of models we investigated are four SIS and SIRS epidemic models of two competitive species with the standard or the mass acting incidence and crossing infection, some complete results were obtained^[33]. One of the results shows that under some conditions, the disease can die out finally by cutting off the inter-infections between the two species or decreasing the inter-transmission coefficients between the two species to a fixed value.

8 Epidemic models combining with ecotoxicology

Starting from 1983, T. Hallam, Z. Ma, etc. investigated the dynamic behavior of population in a polluted environment. They got the threshold between weak persistence in the mean and extinction of aquatic populations in a polluted waters^[34–37]. The mathematical meaning of weak persistence in the mean of a population $x(t)$ is that

$$\limsup_{t \rightarrow +\infty} \frac{\int_0^t x(\tau) d\tau}{t} > 0.$$

[38] investigated an SIS model in a polluted environment to see how the toxicant effects the epidemic dynamic behavior. The model they considered is described as

$$(M_{20}) \quad \begin{cases} \frac{dS}{dt} = B(N, C_0, C_e)N - D(N, C_0, C_e)S - \lambda(C_0)\frac{SI}{N} + \gamma(C_0)I, \\ \frac{dI}{dt} = \lambda(C_0)\frac{SI}{N} - D(N, C_0, C_e)I - \gamma(C_0)I, \\ \frac{dN}{dt} = \gamma(C_0)N\left(1 - \frac{N}{k(C_e)}\right), \\ \frac{dC_0}{dt} = KC_e - (g + m)C_0, \\ \frac{dC_e}{dt} = -hC_e - k_1NC_e + g_1NC_0 + u(t), \end{cases}$$

where $N = S + I$, $B(N, C_0, C_e) = b(C_0) - ar(C_0)\frac{N}{K(C_e)}$, $r(C_0) = B(N, C_0, C_e) - D(N, C_0, C_e)$.

C_e and C_0 are concentrations of the toxicant in the environment and inside the organism's body respectively, they depend on $u(t)$ which is input rate of the toxicant from outside the environment. Here we assume that besides density dependent, the birth rate and death rate will also be effected by the concentrations of the toxicant C_0 and C_e , the coefficients of the infection rate λ , recovered rate λ , recovered rate

γ and the intrinsic growth rate r will be effected by C_0 , the carrying capacity k will be effected by C_e . The last two equations describe the interactive influence among the organism, environment and toxicant^[35]. When the pollution input rate $u(t)$ is know the model M_{20} is a kind of non-autonomous epidemic system.

Theorem 16^[38] For the model (M_{20}), let

$$R = \frac{\lambda(C_0)}{D(N, C_0, C_e) + \gamma(C_0)}, \quad \langle R \rangle^* = \limsup_{t \rightarrow \infty} \frac{\int_0^t R(\tau) d\tau}{t}.$$

- (1) If $\langle R \rangle^* < 1$ then $I(t)$ goes to extinction;
- (2) If $\langle R \rangle^* > 1$ then $I(t)$ is weakly persistent in the mean;
- (3) If $\langle R \rangle^* = 1$ then $I(t)$ is at most barely persistent, which means that either $\lim_{t \rightarrow \infty} I(t) = 0$ or $\limsup_{t \rightarrow \infty} I(t) > 0$ but $\langle I \rangle^* = 0$.

We also proved the existence and global stability of the periodic solution for the model M_{20} under some conditions. The results show that under different conditions, pollution may promote the disease to be spread, but it may also eradicate the disease.

9 The phenomenon of stability switches on some epidemic models with time delay

For the epidemic models with time delay, if we ignore the death rate in the time delay period, then the characteristic equation of the system at the equilibrium usually has the form

$$P(\lambda) + Q(\lambda)e^{-\lambda\tau} = 0, \quad (9.1)$$

where P and Q are usually polynomials. Cooke and van den Driessche found that the stability of this characteristic equation may be changed a finite times when τ increases^[39], this phenomenon is called stability switches, and the stability switches can be determined by a formula deduced by them. But in the reality, when the time delay period is not very short, the death rate should not be ignored. In this case the corresponding characteristic equation is given by

$$P(\lambda, \tau) + Q(\lambda, \tau)e^{-\lambda\tau} = 0. \quad (9.2)$$

Beretta and Kuang found an essential different between the two characteristic equations^[40]. For equation (9.1), it must be ultimately unstable; but equation (9.2) may be ultimately stable. Beretta and Kuang also contributed a geometric method to determine the stability switch and

the ultimate stability, but their method needs some mathematic software to assist for fixed parameters. We investigated further the ultimate stability of a special type of characteristic equation (9.2) where

$$P(\lambda, \tau) = \lambda^2 + a(\tau)\lambda + c(\tau), \quad Q(\lambda, \tau) = b(\tau)\lambda + d(\tau). \quad (9.3)$$

This characteristic equation appear often in some biologic systems with time delay. The results obtained by us show that for this type of characteristic equation, ultimate stability, ultimate unstability and permanent alternation of the stability may all happen, and the criterion has been derived to determine these situations directly from the equations instead of by numerical simulation.

Theorem 17^[41] Under some assumptions (see [41]) which conforms to the common cases, the following is true for the characteristic equation (9.2) with P and Q expressed by (9.3).

(1) If the existent interval of $y(\tau)$ is finite, the equation (9.2) must be ultimately stable;

(2) If the existent interval of $y(\tau)$ is infinite, (9.2) is ultimately stable provided $\limsup_{\tau \rightarrow \infty} D(\tau) < 0$, ultimately unstable provided $\liminf_{\tau \rightarrow \infty} D(\tau) > 0$;

(3) If the existent interval of $y(\tau)$ is infinite, the stability switches of (9.2) will appear forever as τ increases provided $\limsup_{\tau \rightarrow \infty} D(\tau) > 0$ and $\liminf_{\tau \rightarrow \infty} D(\tau) < 0$.

Where $\pm iy(\tau)$ are the pure imaginary eigenvalues, i.e. $\lambda(\tau) = \pm iy(\tau)$, and $y(c)$ is the positive root of the equation:

$$F(y, \tau) \triangleq y^4 - [b^2(\tau) + 2c(\tau) - a^2(\tau)]y^2 + [c^2(\tau) - d^2(\tau)] = 0.$$

We assume that for any $\tau \in R_{+0}$, the equation $F(y, \tau) = 0$ has at most one positive root $y = y(\tau)$, and function $c^2(\tau) - d^2(\tau)$ has at most one zero on R_{+0} . Hence if the function $c^2(\tau) - d^2(\tau)$ has no zero on R_{+0} then the existent set of $y = y(\tau)$ is interval $(0, +\infty)$ when $F(y, \tau) = 0$ has just one positive root $y = y(\tau)$; if $c^2(\tau) - d^2(\tau)$ has just one zero $\tau \in R_{+0}$, then the existent set of $y = y(\tau)$ is interval $(0, \bar{\tau})$ or $(\bar{\tau}, +\infty)$ and $y(\bar{\tau}) = 0$:

$$D(\tau) = \frac{y(\tau)\tau - \theta(\tau)}{2\pi},$$

and $\theta(\tau) \in [0, 2\pi]$ is determined by the equations

$$\begin{cases} \sin \theta = \frac{-b(\tau)y[c(\tau) - y^2] + a(\tau)d(\tau)y}{b^2(\tau)y^2 + d^2(\tau)}, \\ \cos \theta = -\frac{d(\tau)[c(\tau) - y^2] + a(\tau)b(\tau)y^2}{b^2(\tau)y^2 + d^2(\tau)}. \end{cases}$$

Theorem 18^[41] Suppose that the existent interval of $y(\tau)$ is infinite and that $\lim_{\tau \rightarrow \infty} D(\tau) = 0$, then the following conclusions are true.

(1) If the number of the roots of $D(\tau) = 0$ is even, then (9.2) is ultimately stable;

(2) If the number of the roots of $D(\tau) = 0$ is odd, then (9.2) is ultimately unstable;

(3) If equation $D(\tau) = 0$ has infinite number of roots, then the stability switches will appear forever as τ increases.

To show the applications of our method, [41] gave two examples, one is a Juvenile-adult population model, that the unique positive equilibrium (J^*, A^*) might be ultimately stable, which has been showed by Beretta and Kuang in terms of some software^[40]. Applying our method, it is easy to prove the equilibrium is either always stable, or ultimately stable. Another example is an SEIS epidemic model with time delay. By means of our method, it is easy to prove that in any case the endemic equilibrium of this system is ultimately unstable.

We also extended our method to the following more general characteristic equation^[42].

$$P(\lambda, \tau) + Q(\lambda, \tau)e^{-\lambda\tau} + R(\lambda, \tau)e^{-2\lambda\tau} = 0,$$

which may also appear in some epidemic models. The formula, which may differentiate when the stability switches happen, has been deduced, and the method, which determines the ultimate stability for some special characteristic equations, has been obtained.

10 Study on HIV/AIDS

Our group did some work on HIV/AIDS in two ways. One is from the theoretical immunology point of view to investigate the dynamic behavior among the T-cells, antigen presenting cells (APCs) and HIV-1. The following Figure 10.1 shows their interaction network^[43].

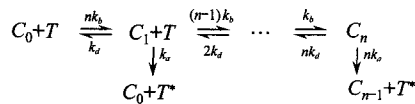

Figure 10.1: The flowchart of the interaction network of an HIV/AIDS model.

Where, the resting T-cells are denoted by T , the healthy and activated T-cells by T^* and the conjugate of an APC bound with j T-cells by C_j . In detail, an APC, either an antigen-primed dendritic cell or a macrophage, has several T-cell binding sites. After invading into *in vivo*,

antigens are detected, taken up, and processed by APCs. The interaction of these APCs and the specific resting T-cells leads to T-cell activation, and then T-cells translate into class T^* from T . The binding rate between T-cells and a free site on an APC is assumed as k_b , then the binding rate of T-cells and an APC which have i free sites will be k_b multiplied by the number of available free sites, i . After being bound, a T-cell can also dissociate with rate k_d , or it can become activated with the rate coefficient k_a . To sum up, the dissociation and activation rates per APC are proportional to the total number of T-cells bound to the APC. It was also assumed that the population size of the APC precursors (C_p) keeps constant according to literatures. Using Ag to represent the concentration of antigen, the description above was translated into the model as follows:

$$(M_{21}) \quad \left\{ \begin{array}{l} \frac{dC_0}{dt} = bC_pV - nk_bC_0T + (k_d + k_a)C_1 - d_cC_0, \\ \frac{dC_j}{dt} = (n - j + 1)k_bC_{j-1}T - [(n - j)k_bT + j(k_d + k_a)]C_j \\ \quad + (j + 1)(k_d + k_a)C_{j+1} - d_cC_j, \quad j = 1, \dots, n - 1, \\ \frac{dC_n}{dt} = k_bC_{n-1}T - n(k_d + k_a)C_n - d_cC_n, \\ \frac{dT}{dt} = a - d_TT - k_bT \sum_{j=0}^{n-1} (n - j)C_j + k_d \sum_{j=1}^n jC_j + \mu k_r T^*, \\ \frac{dT^*}{dt} = k_a \sum_{j=1}^n jC_j - k_r T^*, \\ \frac{dAg}{dt} = (q - eT^*)Ag. \end{array} \right.$$

Using the predigestion technique, we can simplify the system as follows:

$$(M_{22}) \quad \left\{ \begin{array}{l} \frac{ds}{d\tau} = \sigma(v - s), \\ \frac{dx}{d\tau} = \alpha + \left(\frac{s}{1+x} - 1 \right)x, \\ \frac{dv}{d\tau} = \pi \left[\left(\delta' + \frac{\delta(p - \theta_1)v}{1 + pv} \right) \frac{sx}{1+x} - \theta_2 v \right], \end{array} \right.$$

where, s , x , and v are scaled variables which represent the total (scaled) population of antigen presenting sites, the resting T-cells and HIV virus, respectively.

Our model emphasizes the impact of APCs during HIV infection and the cell-to-cell contact manner in transferring of HIV-1 in vivo. The existence and stability of the uninfected steady state and those of the

infected steady states are discussed. The uniform persistence of the system is also proved. By this model, we found the critical strength of the immunity system, under which the individual will be infected even though the dose of invaded HIV Viruses is very small, but above which, will not be infected for a certain dose. We also obtained the different parameter regions to distinguish the cases where the infected person becomes a rapid progress or a long term survivor^[43]. We also investigated the effects of cytokinin and therapy strategy by a model of interaction among the healthy CD4+ T-cells, infected CD4+T-cells, CD8+T-cells, IL-2(interleukin-2), CAF(CD8 antiviral factor) and free virus^[44,45]. The results show that the effects of IL-2 and CAF in the treatment for the infected are limiting, namely, the curative effect will go to saturation when the doses of IL-2 or CAF or both are increased. Our findings also show that for curative effect, CAF is better than IL-2. We also gain some possible reasons for the collapse of the immune system.

Another way of our research for HIV/AIDS is to investigate its spreading rules. We constructed a competition model of HIV with recombination effect and found that the principle of competitive exclusion is no longer valid in the competition between the recombination HIV virus and its parental viruses. The recombination effect makes the mosaic virus can either coexist with their parental viruses or survive alone, which depends on the initial state^[46]. According to this result, we suggest that the most important vaccine is for mosaic virus; and a suggestion of therapy strategy is that first let the parental viruses decrease low enough so that the phase state could be in the attractive region of the equilibrium where the mosaic viruses survive alone, hence the parental viruses may die out by the dynamic behavior itself, then pay attention to eliminate the mosaic virus using the available specific vaccines^[46]. Our results gave a reasonable explanation to the question: why there are two different transmission routes with different B'/C recombinant strains of HIV in China?^[46]

11 Modeling and study for SARS transmission and control in China

SARS (Severe Acute Respiratory Syndrome) is a newly acute infective disease with high potential of transmission to close contacts. This infection first appeared and was transmitted in China in November 2002, and spread rapidly to 31 countries within half a year. Till June 2003 the cumulative number of diagnosed SARS cases is 8454 with 792 deaths in the whole world^[47,48]. It was especially serious in China. The cumulative number of diagnosed cases is 5327 with 343 deaths during about

half a year. In those days of infection peak (middle of May 2003), there were over 100 cases increased per day in Beijing China. In order to provide a reference for the forecast and control to the transmission of SARS in China, our group constructed a model according to the specific situation in China. Our results of research was published to reporters on May 20, 2003, on that day the number of new diagnosed in Beijing still over 100, our report shows that according to the standard of WHO, the travel warning can be removed in the last ten-day period of the June in Beijing, and it was removed on June 23. The number of cumulative diagnosed in the mainland of China estimated by our model is less than 6000, and it is actually 5327.

The difficulties we met in the modeling of SARS were the following:

(1) Because SARS is a new disease, the infectious probability is unknown, and whether the individuals in the exposed compartment have infectivity is not sure; (2) how to select the compartments and how to construct the model such that it fits the situation in China? Especially, how to reflect those effective control measures adopted by the government such as various kinds of quarantines? (3) how to get the data of those parameters which are difficult to quantify, for example, the intensity of the quarantine?

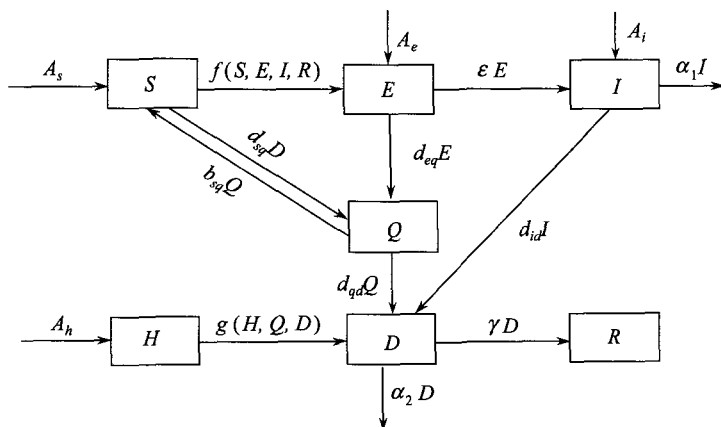

Figure 11.1: The flowchart of our SARS model.

According to the general principle of epidemic modeling and the specific situation for SARS outbreak in China, the flowchart of the model we established is shown in Figure 11.1. Where S, E, I, R are the numbers of susceptibles, exposed, infectious and recovered respectively, they are all in the free environment. Q is the number of quarantined in the hospitals who come from two ways: one is from group E , these individuals are infected by SARS but in the latent period; another way is from the group

S , these individuals without SARS Virus but misdiagnosed as possible SARS patients and they will return to the susceptible group after further medical examinations to rule out SARS Virus, which needs about 10 days. D is the number of diagnosed, who come from both group Q and group I . H is the number of high dangerous susceptibles who are working in the hospitals to take care of SARS patients. In China, the individuals in groups Q , D , and H are all isolated. Because whether the individuals in exposed group have infectivity is not sure during that time, for the sake of safe, we suggested that the infectivity for those individuals is 10 percents comparing with the infectivity of the infectious, On the basis of the flowchart, the model is easily formulated. Let the incidence $F(t) = f(S, E, I, R) = \beta(t)[I(t) + kE(t)]$, where is the infection rate of an individual in group I , it depends on the probability of transmission of SARS which we do not know during that time, and also depends heavily on the intensity of control measures which are difficult to quantify. But the incidence $F(t) = \beta(t)[I(t) + kE(t)]$ expresses the new infected people at the t^{th} day which can be calculated from the daily report of the Ministry of Health in China (MHC); the individuals in $E(t)$ and $I(t)$ will stay in the free environment for 5 days and 3 days respectively, the cumulative number of $E(t)$ and $I(t)$ at t^{th} day may also be calculated from the daily report. Hence we may get the daily data of the infection rate

$\beta(t)$ by $\beta(t) = \frac{F(t)}{I(t) + kE(t)}$, Where $K = 0.1$. Using this back tracking

method we may estimate $\beta(t)$ and all other parameters of our model^[49]. For the term $-d_{sq}D$ in the first equation of the model (M_{22}), usually it should be $-d_{sq}S$, but because S is a huge number, the coefficient d_{sq} must be very small, and this small value will make our model to be an ill system. According to some statistic data, one diagnosed will bring 1.3 individuals to the quarantine group, so instead of $-d_{sq}$ we use $-d_{sq}D$.

Figure 11.2 is the graph of $\beta(t)$, where the continuous curve is the smooth approximation of the actual data reported by MHC, which was obtained by regression analysis method. The origin was April 21, 2003. We can see that $\beta(t)$ decreases very fast which shows that the control measures adopted by our government were very efficient and dramatic.

Using the curve $\beta(t)$ and other parameters we estimated, we did some simulations from the model established by us according to the flowchart in Figure 11.1. Figure 11.3 shows the number of cumulative diagnosed in the mainland of China; Figure 11.4 shows the number of diagnosed in the hospitals. Both origins are April 21, 2003, we can see from these figures that the number of SARS patients increases rapidly during the first three weeks, reaches the peak between May 11 and May 18, 2003, and with the maximal number in the hospitals between 3164 cases and 3220 cases.

Figure 11.2: The graph of the contact rate $\beta(t)$.

Figure 11.3: The number of cumulative diagnosed in the mainland of China.

On the basis of the model, we did some simulations on what will happen if the preventive and control measures were relaxed from May 19, June 10, or if the infected individuals were quarantined one or two days later. We also did some theoretical analysis to a continuous model^[49] and a discrete model^[50] for the SARS spread in China. The reproduction number had been obtained and global stability had been proved.

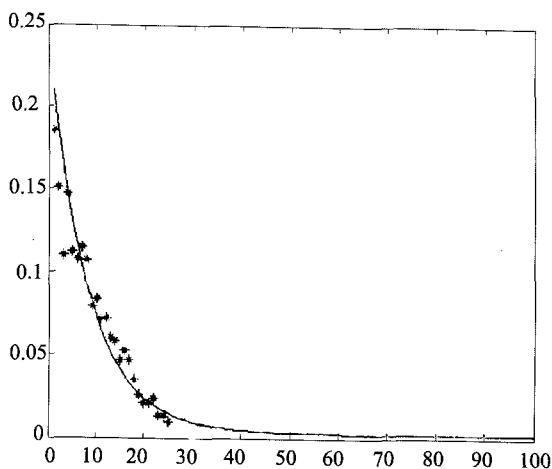
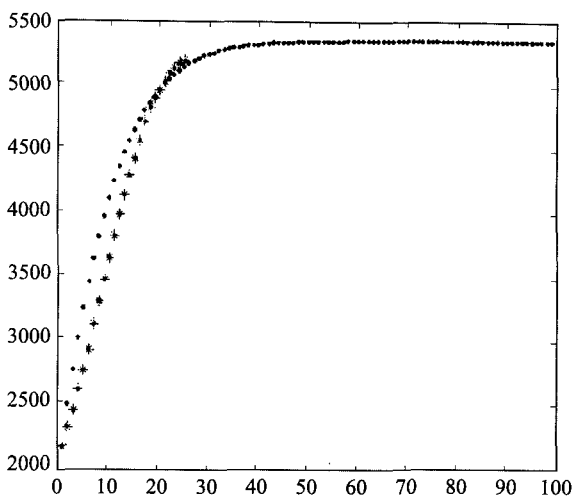
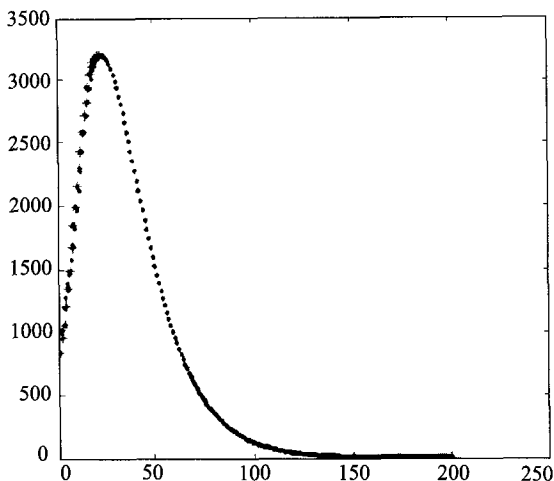

Figure 11.4: The number of diagnosed in the hospitals.

References

- [1] W.O. Kermack, A.G. Mckendrick: Contributions to the mathematical theory of epidemics. Proc. Roy. Soc. 1927 (A115), 700-721.
- [2] K. Dietz: Overall population patterns in the transmission cycle of infectious disease agents. In Population Biology of Infectious Diseases, Springer. 1982.
- [3] J.A.P. Heesterbeek, J.A.J. Metz: The Saturating contact rate in marriage and epidemic models. J. Math. Biol. 1993(31), 529-539.
- [4] W.M. Liu, S.A. Levin, Y. Iwasa: Influence of nonlinear incidence rates upon the behavior of SIRS epidemiological models. J. Math. Biol. 1986(23), 187-204.
- [5] W.M. Liu, H.W. Hethcote, S.A. Levin: Dynamical behavior of epidemiological model with nonlinear incidence rates. J. Math. Biol. 1987(25), 359-380.
- [6] J.Q. Li, Z.E. Ma: Stability analysis for SIS epidemic models with vaccination and constant population size. Discrete and Continuous Dynamical Systems Series B. 2004(4), 635-642.
- [7] J.Q. Li, Z.E. Ma: Global analysis of SIS epidemic models with Variable total population size. Math. Comput. Modelling, 2004(39), 1231-1242.

- [8] J.Q. Li, Z.E. Ma, Y.C. Zhou: Global analysis of SIS epidemic model with a simple vaccination and multiple endemic equilibria. *Acta. Math. Sci.* 2006(26B) 83-93.
- [9] Z. Jin, Z.E. Ma: Epidemic models with continuous and impulse vaccination. To appear.
- [10] Z. Feng, H.R. Thieme: Endemic models with arbitrarily distributed periods of infection, I: general theory. *SIAM. J. Appl. Math.* 2003(61), 803.
- [11] Z. Feng, H.R. Thieme: Epidemic models with arbitrarily distributed periods of infection, II: fast disease dynamics and permanent recovery. *SIAM, J. Appl. Math.* 2003(61), 983.
- [12] L-I, Wu, Z. Feng: Homoclinic bifurcation in an SIQR model for Childhood disease. *J. Diff. Equ.* 2000(168), 150-167.
- [13] H. Hethcote, Z.E. Ma, S. Liao: Effects of quarantine in six endemic models for infectious disease. *Math. Biosci.* 2002(180), 141-160.
- [14] J.S. Muldowney: Compound matrices and ordinary differential equations, Rocky Mount. *J. Math.* 1990(20), 857-972.
- [15] M.Y. Li, J.S. Muldowney: Global stability for the SEIR in epidemiology. *Math. Biosci.* 1995(125), 155-164.
- [16] M.I. Li, H.I. Smith, L. Wang: Global dynamics of an SEIR epidemic model with vertical transmission. *SIAM, J. Appl. Math.* 2001(62), 58-69.
- [17] J. Zhang, Z.E. Ma: Global dynamics of an SEIR epidemic model with saturating contact rate. *Math. Biosci.* 2003(185), 15-32.
- [18] J. Zhang, J.Q. Li, Z.E. Ma: Global dynamics of an SEIR model with immigration of different compartments. *Acta Mathematica Scientia Series B.* 2006(26), No.3 551-567.
- [19] Z.E. Ma, J.P. Liu, J. Li: Stability analysis for differential infectivity epidemic models. *Nonlinear Analysis: RWA*, 2003(4), 841-856.
- [20] J. Li, Z. Ma, et al.: Coexistence of pathogens in sexually transmitted disease models. *J. Math. Biol.* 2003(47), 547-568.
- [21] K. Diftz, D.Schenzle: Proportionate mixing models for age-dependent infection transmission. *J. Math. Biol.* 1985(22), 117-120.
- [22] H.R. Thieme, C. Castillo-Chavez: How may infection-age-dependent infectivity affect the dynamics of *HIV/AIDS*? *SIAM, J. Appl. Math.* 1993(53), 1447-1479.
- [23] Y.C. Zhou, B.J. Song, Z.E. Ma: The global stability analysis for an SIS model with age and infection age structures. *IMA Volume 126*, C. Castillo-Chavez, S. Blower, eds., Springer-Verlag, 2001, 313-335.

- [24] Y.C. Zhou, P. Fergola: Dynamics of a discrete age-structured SIS models. *Discrete and Continuous Dynamical Systems Series B*. 2004(4), 843-852.
- [25] J.L. Ma, Z.E. Ma: Epidemic threshold conditions for seasonally forced SEIR models. *Mathematical Biosciences and Engineering*, 2006(3), 161-172.
- [26] R.M. Anderson, R.M. May, eds.: *Population biology of infectious diseases*, Springer-Verlag, New York, 1982.
- [27] R.M. Anderson, R.M. May: The invasion, persistence, and spread of infectious diseases within animal and plant communities, *Philos. Trans. R. Soc. London* 1986(B314), 533-570.
- [28] E. Venturino: Epidemics in predator-prey models: Disease in the prey, In *mathematical population dynamics: Analysis of heterogeneity, one: Theory of epidemics*, Wuerz publishing, Canada, 1995.
- [29] Y.N. Xiao, L.S. Chen: Modelling and analysis of a predator-prey model with disease in the prey. *Math Biosci.* 2001(170), 59-82.
- [30] R.G. Bowers, M. Begon: A host-pathogen model with free living infective stage, applicable to microbial pest control. *J. Theor. Biol.* 1991(148), 305-329.
- [31] M. Begon, R.G Bowers: Host-host-pathogen models and microbial pest control: the effect of host self-regulation, *J. Theor. Biol.* 1995(169), 275-287.
- [32] L.T. Han, Z.E. Ma, H.M. Hethcote: Four predator-prey models with infectious diseases. *Math. Comput. Modelling*, 2001(34), 849-858.
- [33] L.T. Han, Z.E. Ma, T. Shi: An SIRS epidemic model of two competitive species. *Math. Comput. Modelling*, 2003(37), 87-108.
- [34] T.G. Hallem, C.E. Clarn, G.S. Jordan: Effects of toxicants on populations: a qualitative approach, II. First order kinetics, *J. Math. Biol.* 1983(109), 411-429.
- [35] T.G. Hallam, Z.E. Ma: Persistence in population models with demographic fluctuations. *J. Math. Biol.* 1986(24), 327-339.
- [36] Z.E. Ma, B.J. Sang, T. Hallam: The threshold of survival for systems in a fluctuating environment. *Bull. Math. Biol.* 1989(51), 311-323.
- [37] Z.E. Ma, G.R. Cui, W.D. Wang: Persistence and extinction of a population in a polluted environment. *Math. Biosci.* 1990(101), 5-97.
- [38] F. Wang, Z.E. Ma: Persistence and periodic orbits for an SIS model in a polluted environment. *Comput. Math. Appl.* 2004 (47), 779-792.

- [39] K.L. Cooke, P. Van den Driessche: On zeros of some transcendental equation, *Funkcial. Evac.* 1986(29), 77-90.
- [40] E. Beretta, Y. Kuang: Geometric stability switch criteria in delay differential systems with delay dependent parameters, *SIAM, J. Math. Anal.* 2002(23), 1144-1165.
- [41] J.Q. Li, Z.E. Ma: Ultimate stability of a type of characteristic equation with delay dependent parameters. *J. Syst. Sci. and Complexity*, 2006(19), 137-144.
- [42] J.Q. Li, Z.E. Ma: Stability switches in a class of characteristic equations with delay-dependent parameters. *Nonlinear Anal. RWA*, 2004(5), 389-408.
- [43] J. Lou, Z.E. Ma, Y.M. Shao, L.T. Han: Modelling the interaction of T-cells, Antigen presenting cells, and HIV-1 in Vivo. *Comput. Math. Appl.* 2004(48), 9-33.
- [44] J. Lou, Z.E. Ma, Y.M. Shao: HIV-1 population dynamics in Vivo: implications for pathogenesis, effect of cytokine and therapy strategy. *J. Biol. Syst.* 2004(12), 315-333.
- [45] J. Lou, Z.E. Ma, Y.M. Shao, L.T. Han: The impact of the CD8+ cell non-cytotoxic antiviral response (CNAR) and cytotoxic T lymphocyte (CTL) activity in a cell-to-cell spread model for HIV-1 with a time delay. *J. Biol. Syst.* 2004(12), 73-90.
- [46] F. Wang, Z.E. Ma: A competition model of HIV with recombination effect. *Math. Comput. Modelling*, 2003(38), 1051-1065.
- [47] WHO and CDC, Available from <http://www.moh.gov.cn/was40/detail?record=14&channelid=8085&searchword=%B7%B5%E4%D2%DF%C3%E7>.
- [48] MHC, Available from <http://www.moh.gov.cn/zhg-/xgxx/fzszjs/1200306030008.htm>.
- [49] J. Zhang, J. Lou, Z.E. Ma, J.H. Wu: A compartmental model for the analysis of SARS transmission patterns and outbreak control measures in China. *Appl. Math. Comput.* 2005(162), 909-924.
- [50] Y.C. Zhou, Z.E. Ma, F. Brauer: A discrete epidemic model for SARS transmission and control in China. *Math. Comput. Modelling*, 2004(40), 1491-1506.