

Chapter 1

The Civil Engineer

The first modern civil engineer in Great Britain was John Smeaton (1724–1792); his life work was memorialised in 1994 by the dedication of a plaque in the north aisle of Westminster Abbey. Windows above commemorate Sir Benjamin Baker (the Forth Bridge), Parsons (the steam turbine), Lord Kelvin and Sir Henry Royce; nearby are memorials to Thomas Telford, James Watt, Isambard Kingdom Brunel and George and Robert Stephenson; this is the ‘Engineers Corner’ of the Abbey. Close at hand are architects (Sir George Gilbert Scott, Sir Charles Barry, John Pearson) and scientists and mathematicians – the monument to Newton is justly magnificent.

It is right that architects, engineers, scientists and mathematicians should be grouped together. Some activities involve all four of the professions, and, in particular, it is sometimes hard to distinguish between the work of engineers and scientists. Engineers use Newton’s mathematics and Faraday’s physical laws; engineers and scientists have a common technical language to describe the tools at their disposal. However, there is a difference in the way those tools are deployed. Scientists use the tools to deepen understanding of their own subject, while engineers use the same tools in order to do something, whether it be to design a turbine blade, an electronic circuit, or a radio telescope; to drive a tunnel under the Channel; or to create a great building – a Gothic cathedral or a steel-framed skyscraper.

Smeaton’s scientific work, recognised by his election to the Royal Society at the early age of 28, resulted directly from his need to establish a theoretical basis for his engineering projects – it is in this sense that he may be described as a modern engineer. In the seventeenth century the Royal

Society, and in France the *Académie*, were in no doubt that the ‘science’ their members studied should be of immediate and practical use; this, indeed, was the whole intent of Francis Bacon’s ‘new philosophy’. However, the split between ‘science’ and ‘engineering’ widened quickly, and as early as 1783, for example, Cambridge University created a Professorship of Natural Experimental Philosophy to ensure that engineering developed as a discipline in its own right. Earlier, in 1749, a technical university had been established at Mézières in France in order to teach hydraulics, earthworks and surveying to young army officers (and the great *Écoles*, and the *Polytechnique*, were established before the turn of the century).

However, the theory taught in the universities in the eighteenth century was not adequate for those engineers engaged in ‘the art of directing the great sources of power in Nature for the use and convenience of man’ (to use Thomas Telford’s words of 1828 as first President of the Institution of Civil Engineers). An engineer in charge of a major project, well-schooled though he may have been, was forced to make his own experiments and to develop his own scientific theory. Smeaton was particularly well-read, and his library included major works from both sides of the Channel (Newton’s *Principia*, of course, but also Bélidor’s *Architecture hydraulique* of 1735, Desagulier’s *Experimental Philosophy* of 1744, a Vitruvius, and so on). However, it was known that a great range of engineering problems required urgent attention, and the Royal Society, and the *Académie*, offered prizes from time to time for their solution.

The four great problems in structural engineering throughout the eighteenth century were the strength of beams, the strength of columns, the thrust of arches and the thrust of soil (that is, the behaviour of soil behind a retaining wall, a problem in the field of what is now called soil mechanics). When Charles Coulomb, as a recent graduate of Mézières, was sent as a young army officer to fortify the island of Martinique (against the attacks, among others, of the British), he found that he lacked the theory for each of these four problems. He needed solutions in order to design his fortifications; on his return to Paris after nine years abroad, he presented his contributions to theory to the *Académie* in a notable paper of 1773. (The fourth section of this paper is a fundamental contribution to the science of soil mechanics, of which Coulomb is regarded by engineers as the founder. He is remembered by physicists – who do not know of him as a civil engineer – for his later work on electric charges.)

Smeaton, like Coulomb, was interested in a broad range of topics, and, throughout his life, he presented his scientific work to the Royal Society. Eighteen papers were published in the *Philosophical Transactions* between 1750 and 1788 (Coulomb read 32 memoirs to the *Académie/Institut* between 1773 and 1806). In his papers, Smeaton was concerned with three main topics: instruments, astronomy and mechanics. He was interested in problems concerned with navigation on the one hand, and with astronomical observation and instrumentation on the other, and his papers on these subjects, early and late in his career, were careful and intricate. Between these publications, however, three papers are of a different class; they deal, in essence, with fundamental questions of theoretical mechanics.

It was the great paper of 1759 (soon to be translated and published in France), ‘An experimental enquiry concerning the natural powers of water and wind to turn mills’, that was rewarded with the Copley Medal, the highest award bestowed by the Royal Society for original research – Smeaton was then aged 35. Coulomb’s work had been in solid mechanics; Smeaton was dealing with fluids, and once again the basic science had not been established which could be used for engineering design. Smeaton knew of existing French theory, and his own experiments demonstrated clearly where this was incorrect. In fact his own theoretical enquiries at this time did not resolve some of the basic issues, and it was Borda in France, 10 years later, who contributed the mathematics which led finally to the turbine. What was hazy in 1759 were the concepts of momentum, energy and work, and how these should be expressed mathematically; Smeaton got far enough in his analyses to be able to make correct design decisions for mills.

In all of this scientific work are reflected the difficulties that confront an engineer when he expands a basic store of science, great though that may be, to tackle problems not met with before. Smeaton’s eighteen papers are valuable in themselves, and they show how he was contributing to his profession, establishing ideas which could be understood, taught and used by his successors. But the papers are in effect by-products of the design and execution of a great range of civil engineering works.

Perhaps the best known of Smeaton’s works is his first lighthouse of 1756/9, the Eddystone. His own *Narrative of the Building and a Description of the Construction of the Edystone Lighthouse*, published as a book in 1791, shows how an engineer achieves something new. The Trustees had to agree to a house built in stone; Smeaton himself went to Plymouth to survey the Rock (he invented his own surveying apparatus for this purpose);

PL. I.

Sav. Etrang 1773 Pl. 302. Pl. XV.

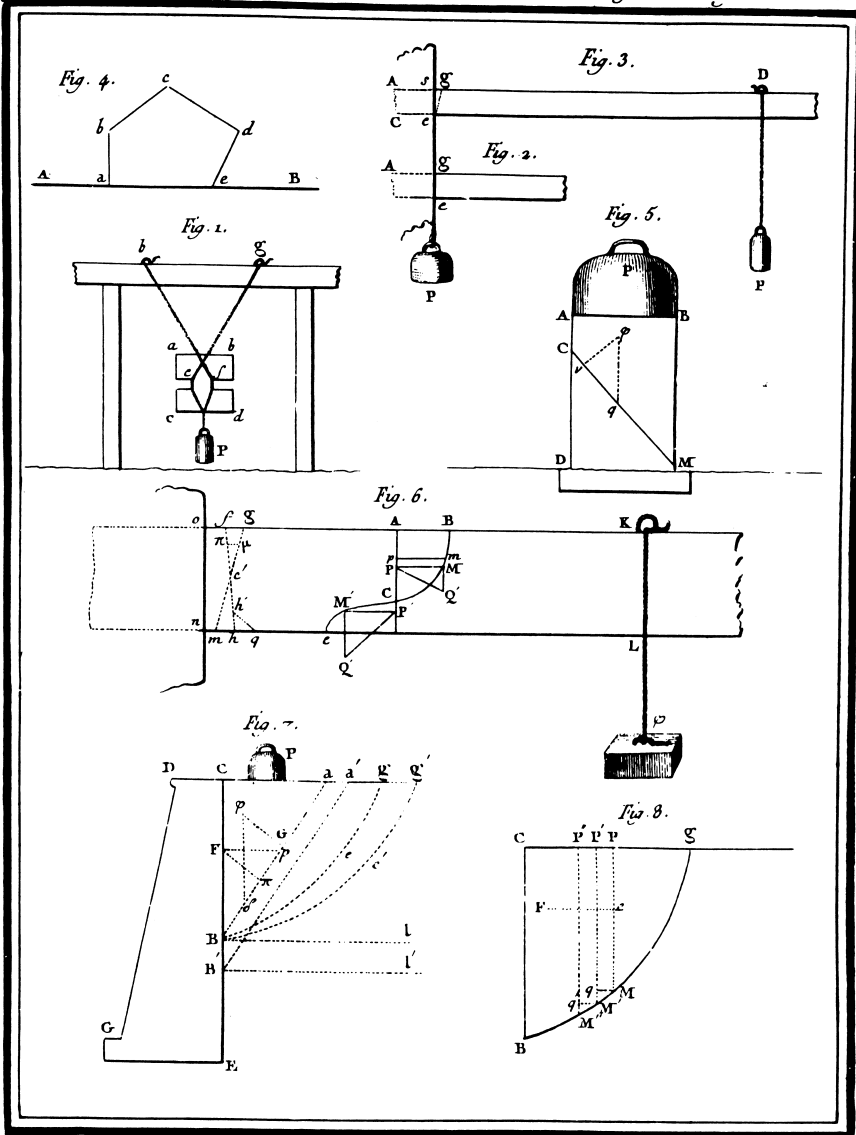

C^{te} Hawsard Sculp.

Plate I of Charles Coulomb's first scientific paper, presented to the French Academy in 1773 and published in 1776. The plate illustrates three of the four problems discussed by Coulomb – illustrations of masonry arches were grouped on a second sheet.

Figure 3 shows a beam, embedded in a wall at the left-hand end, and carrying a load near its tip – how could the breaking load of this cantilever beam be calculated? A tension test, shown in Fig. 1, would give the fracture strength of the material – could this fracture strength be correlated with the bending strength of the beam? Coulomb showed how such a prediction must be made, and Fig. 6 gives the technical illustration from which he developed his theory.

Similarly, Coulomb was concerned with the calculation of the breaking load of a stone column loaded vertically, as in Fig. 5, and he showed that fracture would occur along an inclined plane CM, at an angle which could be predicted from the properties of the material.

The third problem tackled by Coulomb was the design of retaining walls to hold back soil (Fig. 7). To design the wall, it was necessary to evaluate the thrust of the soil, and Coulomb's 1773 paper is regarded as fundamental to the development of the science of soil mechanics.

These four problems – the strength of beams, the strength of columns, and the thrust of soil, together with the thrust of arches – were the most important problems of civil engineering in the eighteenth century. They arose in a military context, in the design of fortifications, but their solutions opened up a range of applications in the general field of structural engineering.

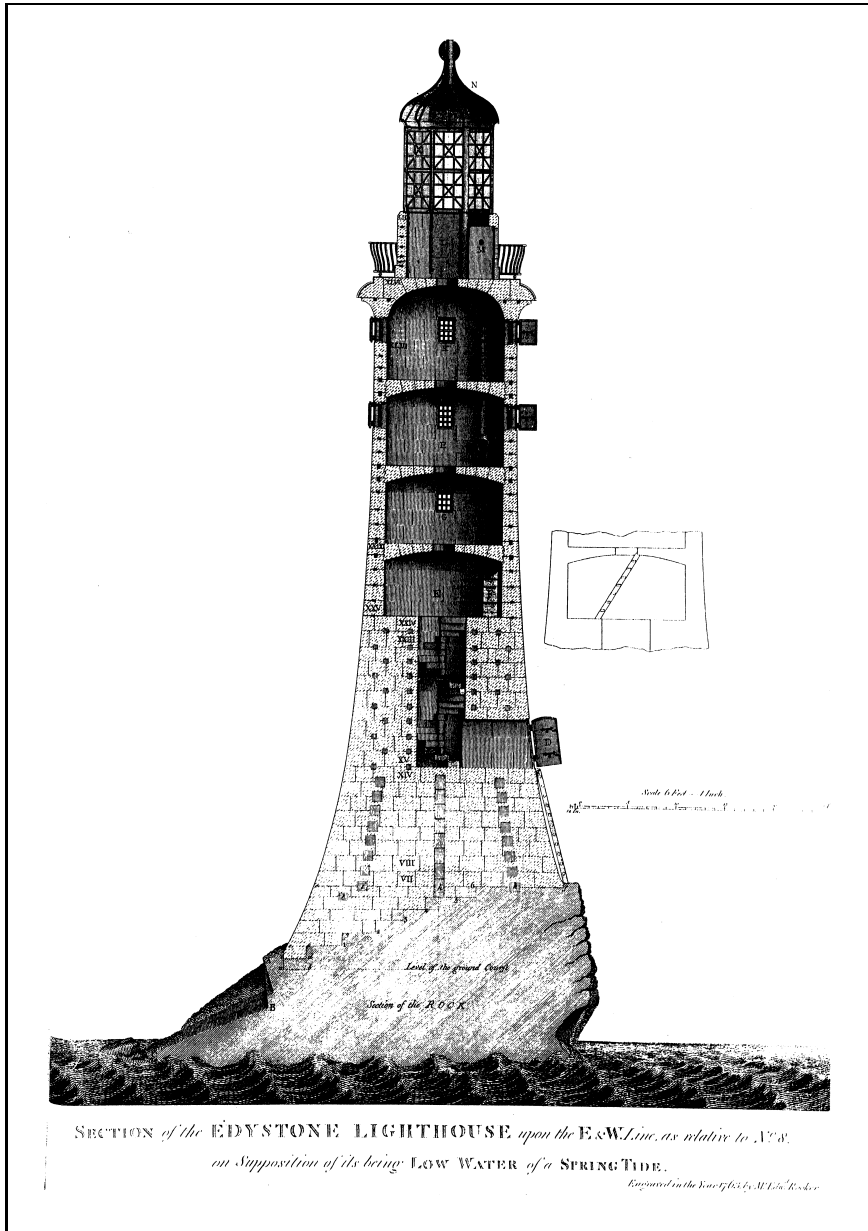

Eddystone lighthouse: An engraving from a drawing by Smeaton.

The Eddystone Rocks are part of a reef of red granite, 14 miles south of Plymouth; they are largely covered at high tide, and have always been a hazard to shipping. A first lighthouse was built on the rocks in 1696, and was destroyed in a storm in 1703. A second lighthouse, in timber, was completed in 1709, and survived until 1755 when it was destroyed by fire. Smeaton was relatively unknown when, at the age of 31, he was commissioned to design a new lighthouse, and he was determined to use stone, both for its weight which would resist the forces of wind and sea, and because it would not burn.

The first problem Smeaton faced was to anchor the stones securely to the rock base. Six steps were cut in this rock, and the steps filled with massive blocks, weighing between 1 and 2 tons, dovetailed together and to the rock. The seventh course was the first complete course of the lighthouse; the exposed blocks were of granite, and the inner of Portland stone. Entrance to the house was above level 14, and a spiral stair led to the succession of four chambers above level 24; these living quarters were enclosed by a circular wall consisting of single blocks of granite. Access between chambers was by means of a movable ladder.

The lighthouse was commissioned in 1759, and survived for well over a century – it was then found that the base rock was in a serious condition. Smeaton's tower itself was in good condition, and the upper parts were taken down and rebuilt on Plymouth Hoe, after a replacement tower had been completed in 1882.

he devised an ingenious interlocking of each course of stone to confer stability on the whole structure; he made experiments, and finally determined the precise mix of lime and pozzolana to form a mortar that would set under sea water; and he considered the effects of wind and waves in his choice of a continuously curved profile for the lighthouse. Finally, he made sure that the work was prosecuted well and efficiently – engineers' tasks do not stop with the conceptual ideas, nor yet when those ideas have been clothed with design calculations and drawings; engineers must ensure that the projects are actually achieved.

For the twenty-five years following the completion of the Eddystone lighthouse, that is, from 1760 to 1783, Smeaton was intensely occupied with engineering projects. He designed more than 50 watermills and windmills, and some dozen steam engines for water supply and pumping. These are what would now be called mechanical engineering works, and of course gave rise to those questions of momentum and power to which he tried to find answers. In the civil engineering field, Smeaton designed four major public bridges, including the three fine masonry arches at Coldstream, Perth and Banff; there were also half a dozen minor bridges in stone or brick, and two aqueducts. He was responsible for the Forth and Clyde Canal, and for substantial improvements to several river navigations; and his works include major harbours, piers and fen drainage schemes. Before 1760 the profession of civil engineering hardly existed; a decade later recognisably modern consulting engineers could be seen, of whom Smeaton was pre-eminent. Such men, then as now, travelled to where their skills were needed; they made designs on the basis of their store of knowledge, and, if that store were insufficient, they made their own theory and experiments and contributed to the science of their subject; and they made sure, if necessary with assistants, that the work was properly done.

Engineers cannot work alone. Mention has been made of the Institution of Civil Engineers which in 1828 formally established a channel for the exchange of professional information. Much earlier, in 1771, an informal Society of Civil Engineers had been established; Smeaton was a founder member, and he was a regular attender of meetings until his death, when the group was renamed the Smeatonian Society. It was in essence an eighteenth-century dining club, and as such it still exists today. There was, however, a vital function – the club provided the opportunity for a group of civil (that is, non-military) engineers to discuss their work.